

# Chapter ~~28~~->26

## Direct Current Circuits

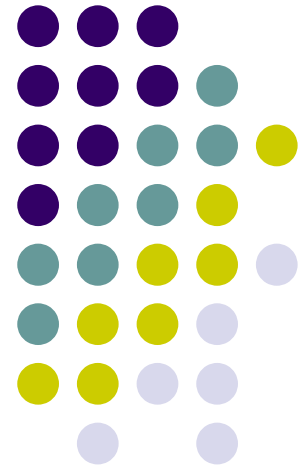

# PHYS 2321

## Week 8: DC Circuits / Magnetic Fields

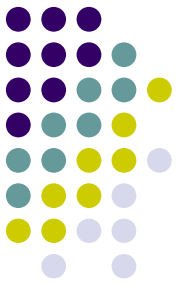

### Day 1 (Wed) Outline

1) Hwk: Ch. 25 P. 2,3,6,9,12-14,16,19,28,29,33,47,55

Read 25-1 to 25-5, 25-8

Ch. 26 MisQ 1-9 odd, Read 26-1 to 26-4

Ch. 26 P. 1,2,5,7,12,17,31 Due Friday.

2) Return Quiz 3 on capacitance and current

3) DC Circuits

a. Batteries and EMF

b. Resistors in series and parallel

c. Junction rule and Loop rule

Due  
Today

Notes: Quiz 3 mean = 6.6/8.0

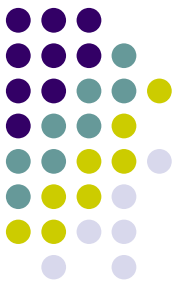

# Direct Current

- When the current in a circuit has a constant direction, the current is called ***direct current***
  - Most of the circuits analyzed will be assumed to be in *steady state*, with constant magnitude and direction
- Because the potential difference between the terminals of a battery is constant, the battery produces direct current
- The battery is known as a source of emf

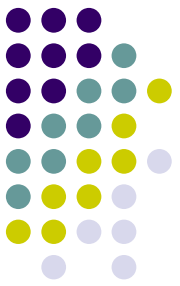

# Electromotive Force

- The electromotive force (emf),  $\varepsilon$ , of a battery is the maximum possible voltage that the battery can provide between its terminals
  - The emf supplies energy, it does not apply a force
- The battery will normally be the source of energy in the circuit
- The positive terminal of the battery is at a higher potential than the negative terminal
- We consider the wires to have no resistance

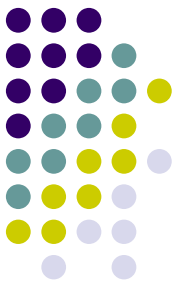

# Internal Battery Resistance

- If the internal resistance is zero, the terminal voltage equals the emf
- In a real battery, there is internal resistance,  $r$
- The terminal voltage,  $\Delta V = \varepsilon - Ir$ 
  - Use the active figure to vary the emf and resistances and see the effect on the graph

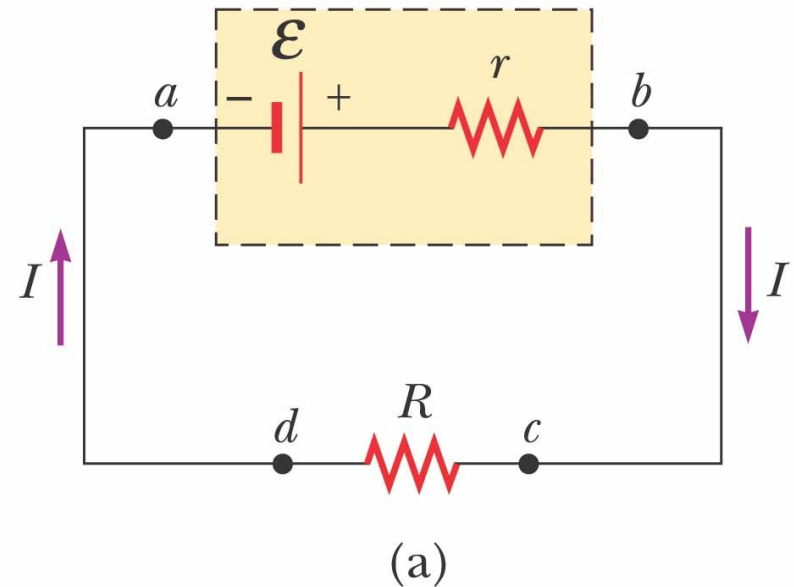

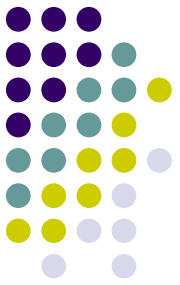

# Active Figure 28.1

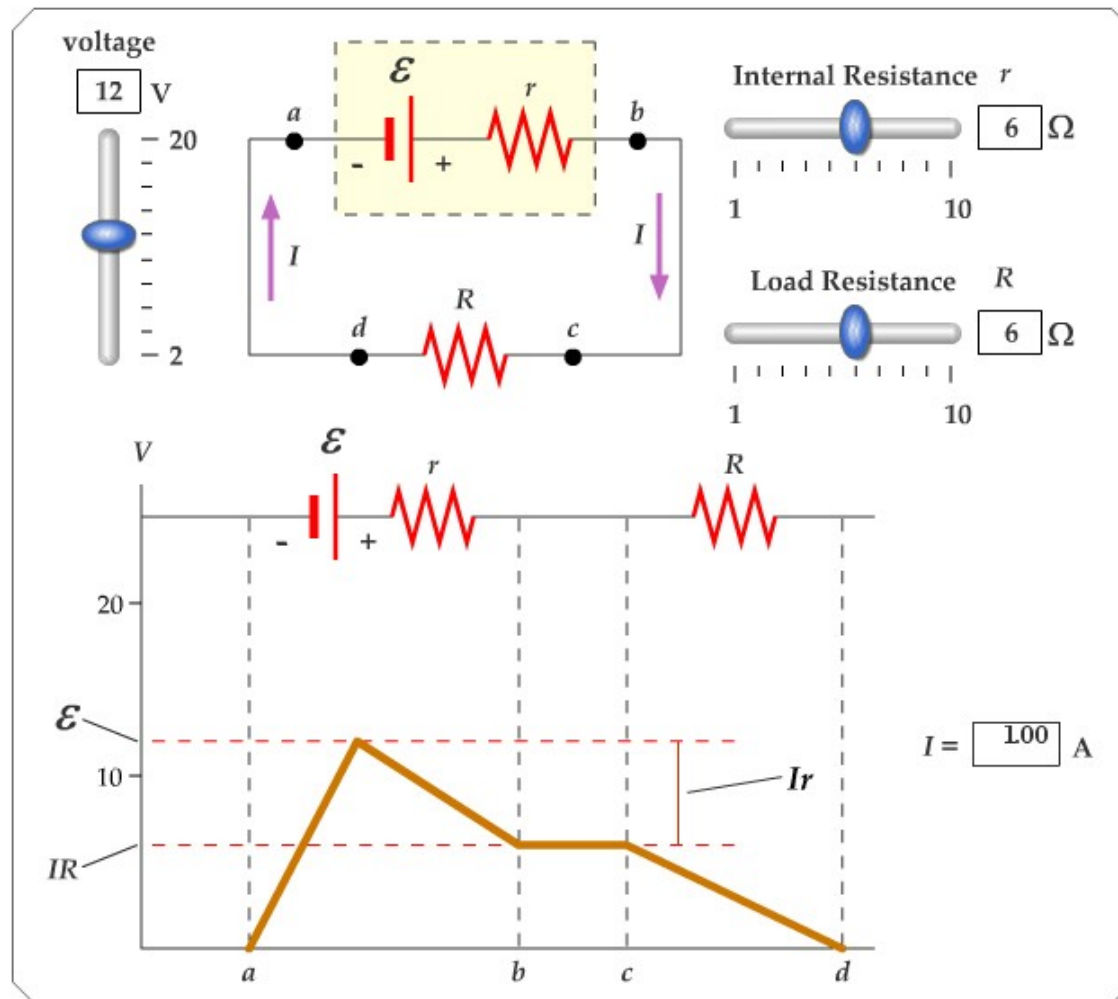

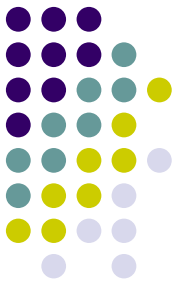

# EMF, cont

- The emf is equivalent to the *open-circuit* voltage
  - This is the terminal voltage when no current is in the circuit
  - This is the voltage labeled on the battery
- The actual potential difference between the terminals of the battery depends on the current in the circuit

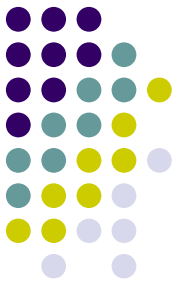

# Load Resistance

- The terminal voltage also equals the voltage across the external resistance
  - This external resistor is called the *load resistance*
  - In the previous circuit, the load resistance is just the external resistor
  - In general, the load resistance could be any electrical device
    - These resistances represent *loads* on the battery since it supplies the energy to operate the device containing the resistance



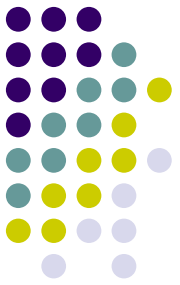

# Power

- The total power output of the battery is

$$P = I\Delta V = I(R_{tot}^2)$$

- This power is delivered to the external resistor ( $I^2 R$ ) and to the internal resistor ( $I^2 r$ )
- $I^2(R_{tot}) = I^2 R + I^2 r$

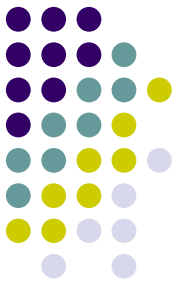

# Resistors in Series

- When two or more resistors are connected end-to-end, they are said to be in *series*
- For a series combination of resistors, the currents are the same in all the resistors because the amount of charge that passes through one resistor must also pass through the other resistors in the same time interval
- The potential difference will divide among the resistors such that the sum of the potential differences across the resistors is equal to the total potential difference across the combination

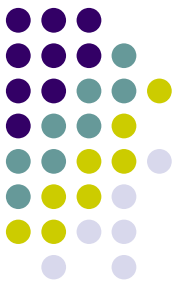

# Resistors in Series, cont

- Potentials add
  - $\Delta V = IR_1 + IR_2$   
 $= I(R_1 + R_2)$
  - Consequence of Conservation of Energy
- The equivalent resistance has the same effect on the circuit as the original combination of resistors

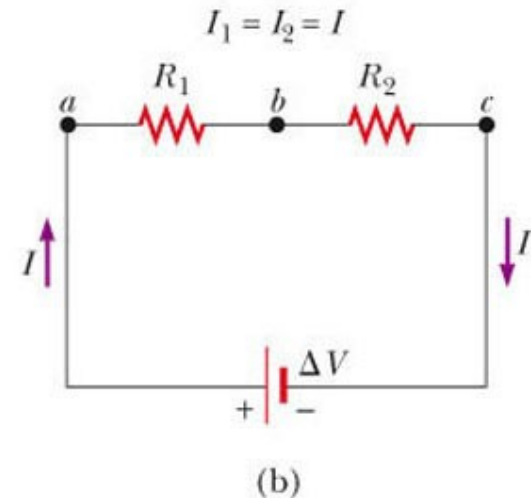

# Resistors in Series – Example

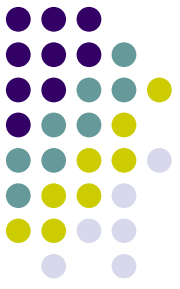

- Use the active figure to vary the battery voltage and the resistor values
- Observe the effect on the currents and voltages of the individual resistors

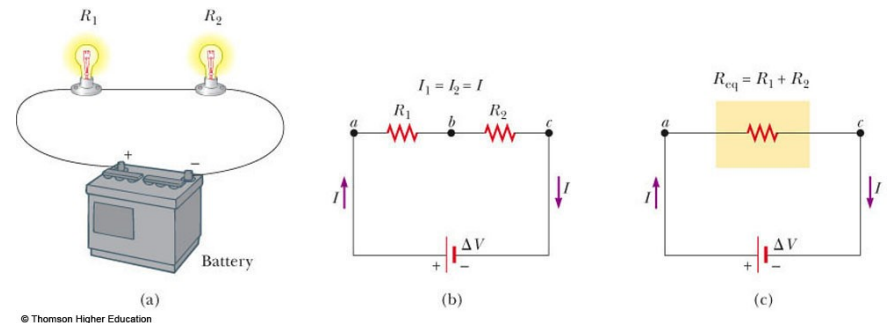

**PLAY  
ACTIVE FIGURE**

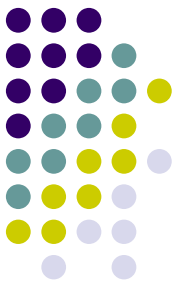

# Equivalent Resistance – Series

- $R_{\text{eq}} = R_1 + R_2 + R_3 + \dots$
- The equivalent resistance of a series combination of resistors is the algebraic sum of the individual resistances and is always greater than any individual resistance
- If one device in the series circuit creates an open circuit, all devices are inoperative

# Equivalent Resistance – Series

## – An Example

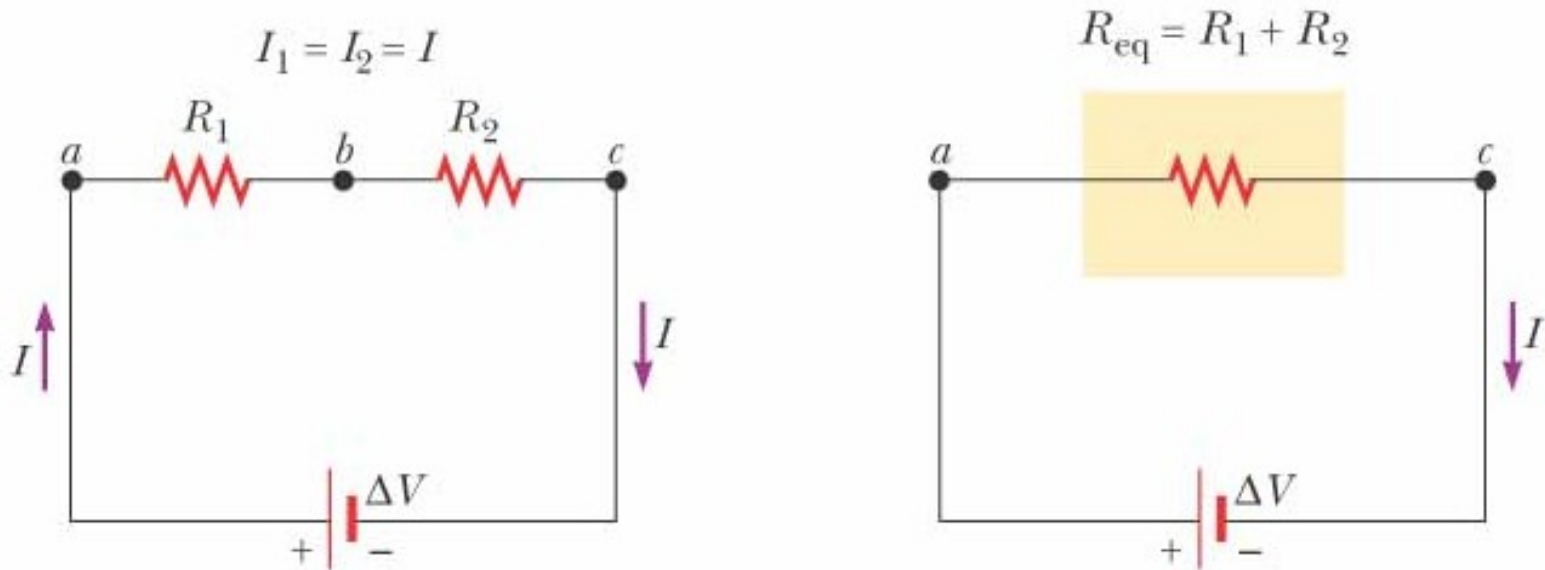
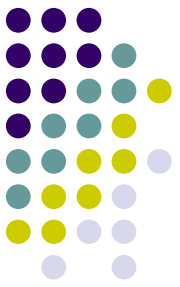

- Two resistors are replaced with their equivalent resistance

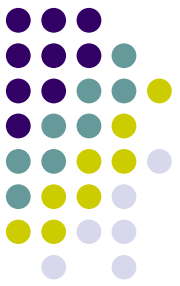

# Some Circuit Notes

- A local change in one part of a circuit may result in a global change throughout the circuit
  - For example, changing one resistor will affect the currents and voltages in all the other resistors and the terminal voltage of the battery
- In a series circuit, there is one path for the current to take
- In a parallel circuit, there are multiple paths for the current to take

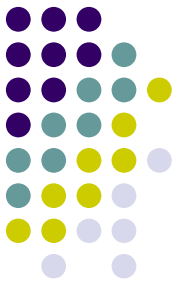

# Resistors in Parallel

- The potential difference across each resistor is the same because each is connected directly across the battery terminals
- A **junction** is a point where the current can split
- The current,  $I$ , that enters a point must be equal to the total current leaving that point
  - $I = I_1 + I_2$
  - The currents are generally not the same
  - Consequence of Conservation of Charge



# Equivalent Resistance – Parallel, Examples

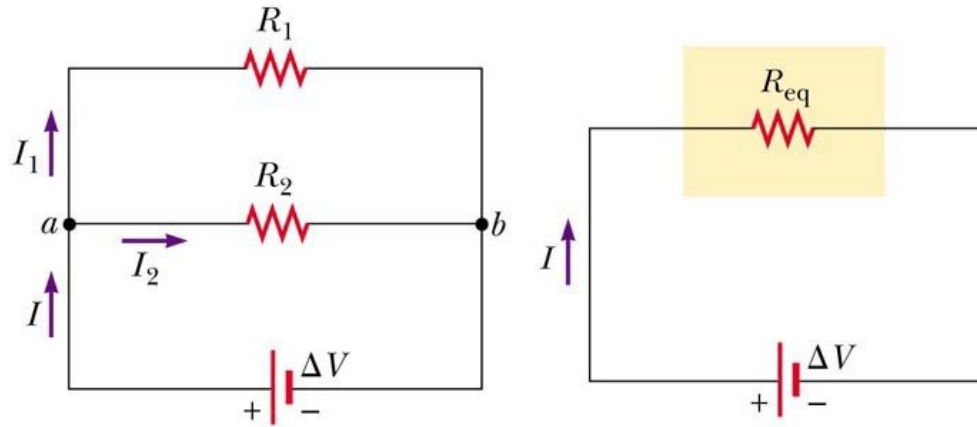
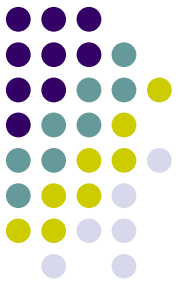

- Equivalent resistance replaces the two original resistances

# Equivalent Resistance – Parallel

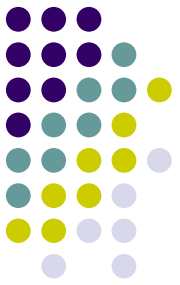

- Equivalent Resistance

$$\frac{1}{R_{eq}} = \frac{1}{R_1} + \frac{1}{R_2} + \frac{1}{R_3} + \dots$$

- The inverse of the equivalent resistance of two or more resistors connected in parallel is the algebraic sum of the inverses of the individual resistance
  - The equivalent is always less than the smallest resistor in the group

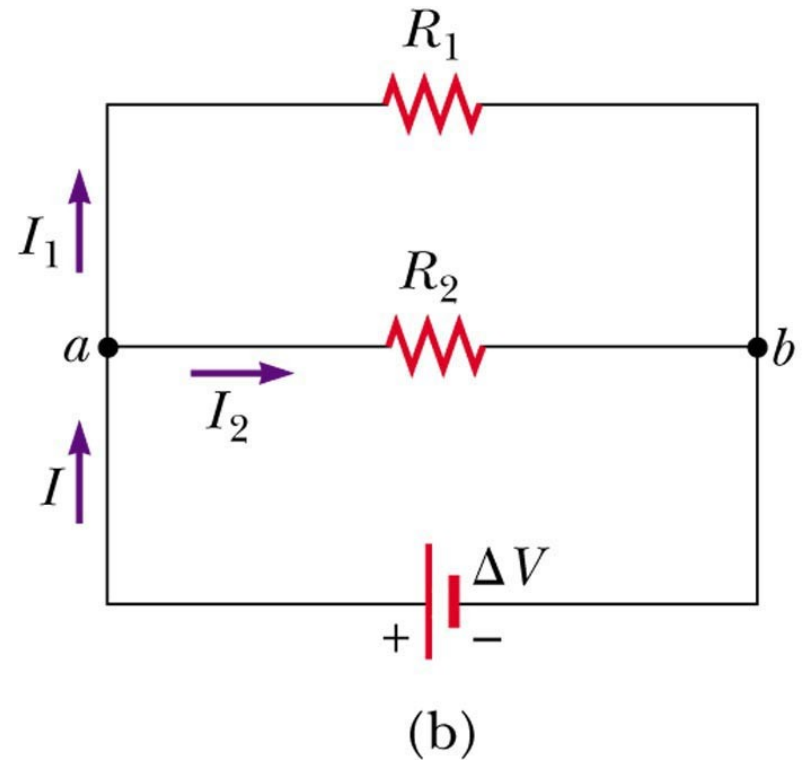

# Resistors in Parallel – Example

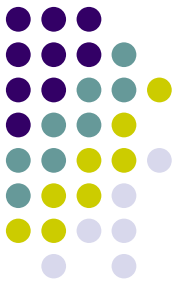

- Use the active figure to vary the battery voltage and the resistor values
- Observe the effect on the currents and voltages of the individual resistors

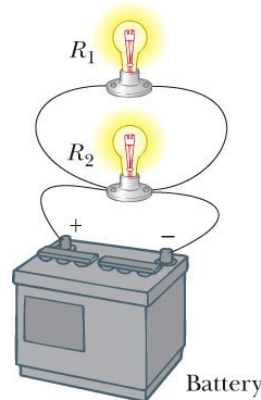

(a)

© Thomson Higher Education

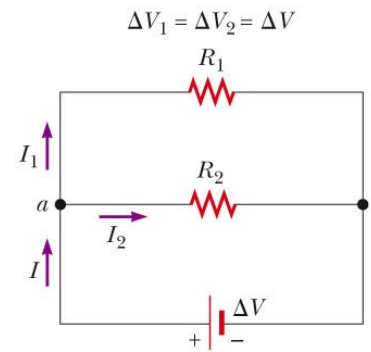

(b)

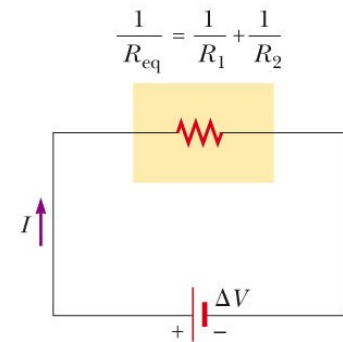

(c)

**PLAY  
ACTIVE FIGURE**

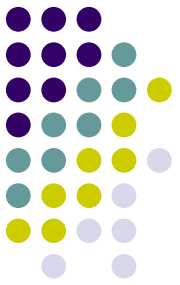

# Resistors in Parallel, Final

- In parallel, each device operates independently of the others so that if one is switched off, the others remain on
- In parallel, all of the devices operate on the same voltage
- The current takes all the paths
  - The lower resistance will have higher currents
  - Even very high resistances will have some currents
- *Household circuits* are wired so that electrical devices are connected in parallel

# Combinations of Resistors

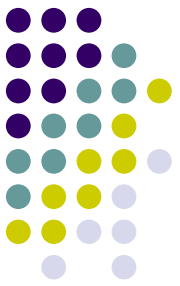

- The  $8.0\text{-}\Omega$  and  $4.0\text{-}\Omega$  resistors are in series and can be replaced with their equivalent,  $12.0\ \Omega$
- The  $6.0\text{-}\Omega$  and  $3.0\text{-}\Omega$  resistors are in parallel and can be replaced with their equivalent,  $2.0\ \Omega$
- These equivalent resistances are in series and can be replaced with their equivalent resistance,  $14.0\ \Omega$

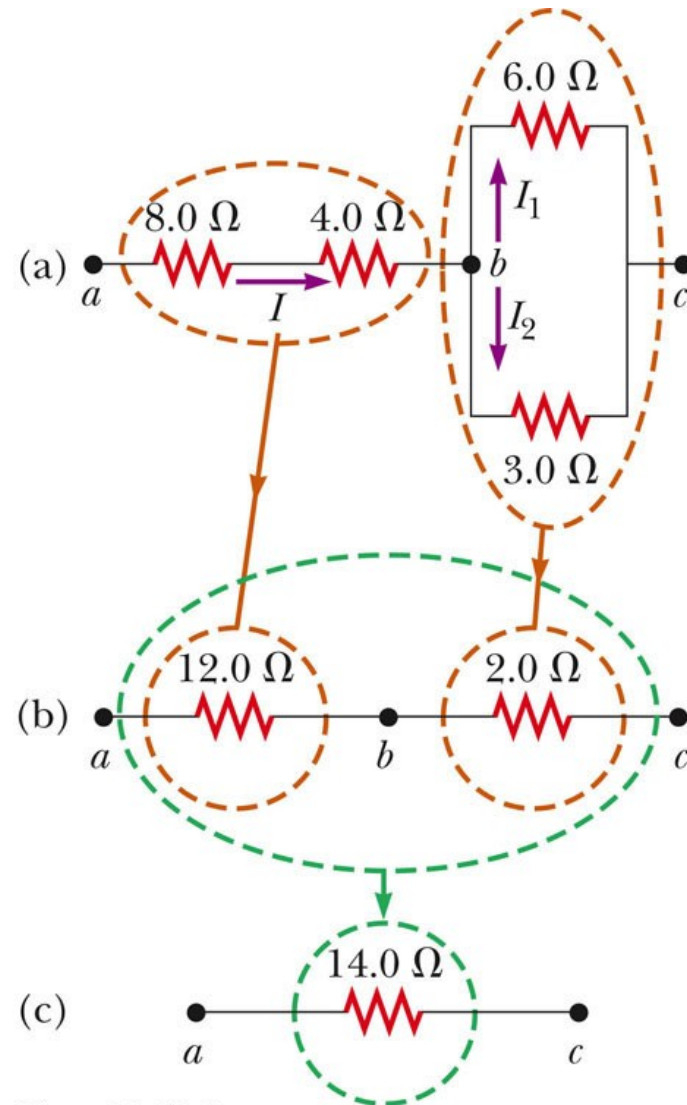

# Gustav Kirchhoff

- 1824 – 1887
- German physicist
- Worked with Robert Bunsen
- They
  - Invented the spectroscope and founded the science of spectroscopy
  - Discovered the elements cesium and rubidium
  - Invented astronomical spectroscopy

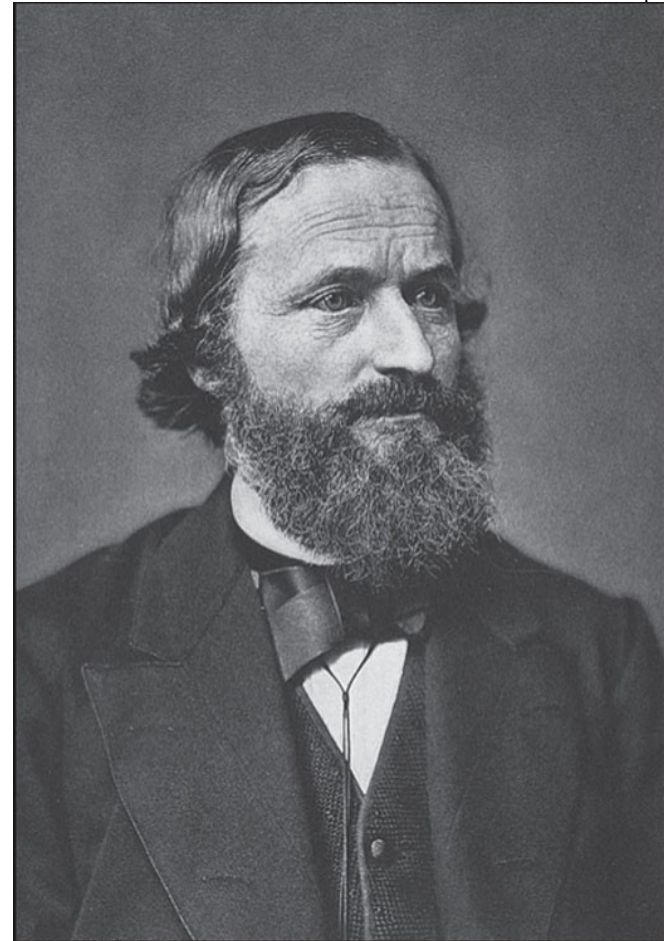

© Thomson Higher Education

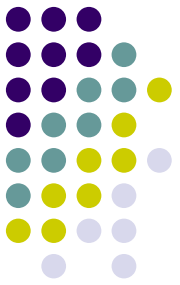

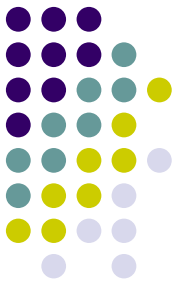

# Kirchhoff's Rules

- There are ways in which resistors can be connected so that the circuits formed cannot be reduced to a single equivalent resistor
- Two rules, called **Kirchhoff's rules**, can be used instead

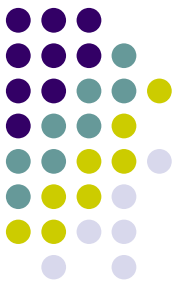

# Kirchhoff's Junction Rule

- Junction Rule
  - The sum of the currents at any junction must equal zero
    - Currents directed into the junction are entered into the -equation as +I and those leaving as -I
    - A statement of Conservation of Charge
  - Mathematically,  $\sum_{junction} I_i = 0$



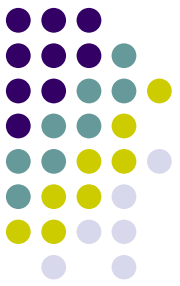

# More about the Junction Rule

- $I_1 - I_2 - I_3 = 0$
- Required by Conservation of Charge
- Diagram (b) shows a mechanical analog

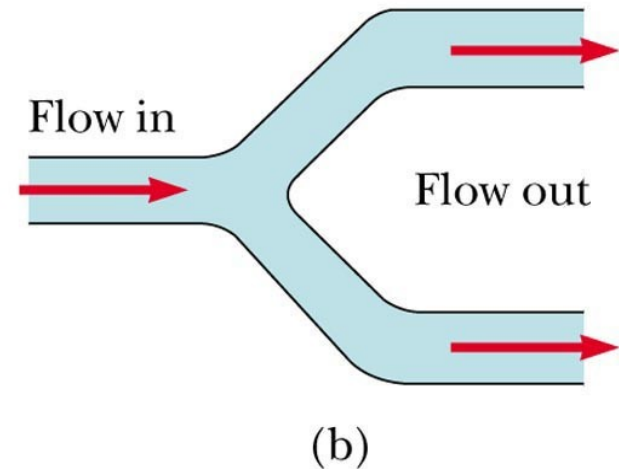
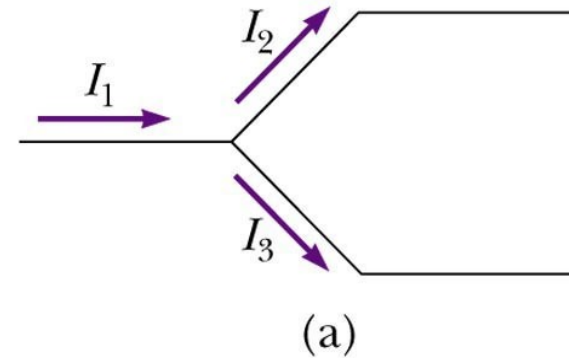

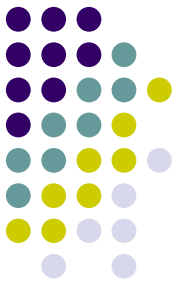

# Kirchhoff's Loop Rule

- Loop Rule
  - The sum of the potential differences across all elements around any closed circuit loop must be zero
    - A statement of Conservation of Energy
- Mathematically, 
$$\sum_{closedloop} \Delta V_i = 0$$

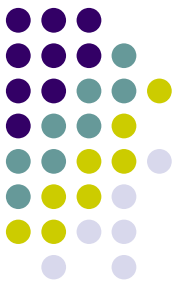

# More about the Loop Rule

- Traveling around the loop from  $a$  to  $b$
- In (a), the resistor is traversed in the direction of the current, the potential across the resistor is  $-IR$
- In (b), the resistor is traversed in the direction opposite of the current, the potential across the resistor is  $+IR$

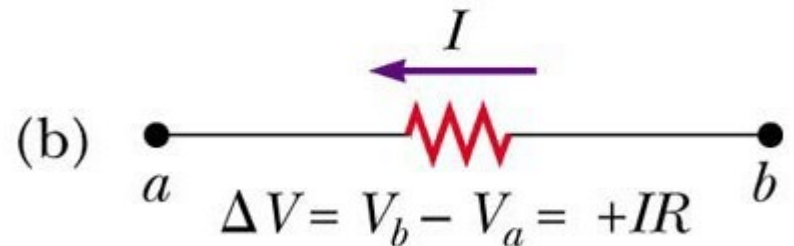
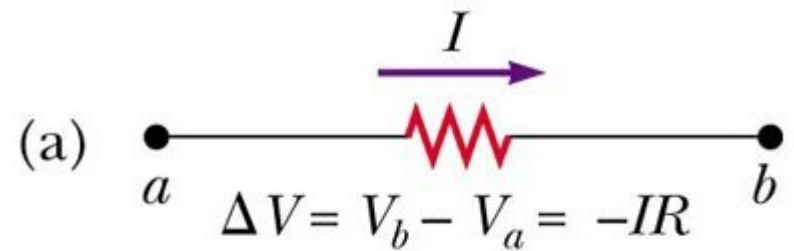

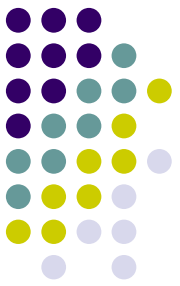

# Loop Rule, final

- In (c), the source of emf is traversed in the direction of the emf (from  $-$  to  $+$ ), and the change in the electric potential is  $+\mathcal{E}$
- In (d), the source of emf is traversed in the direction opposite of the emf (from  $+$  to  $-$ ), and the change in the electric potential is  $-\mathcal{E}$

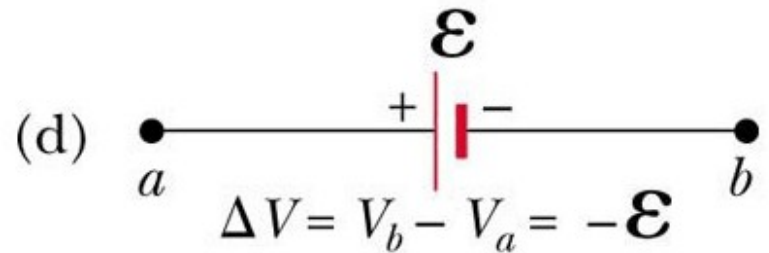
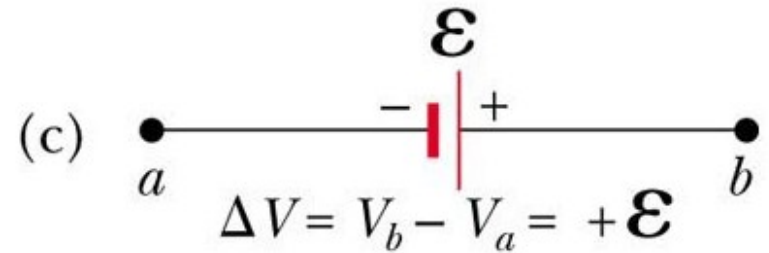

# Junction Equations from Kirchhoff's Rules

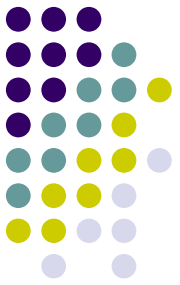

- Use the junction rule as often as needed, so long as each time you write an equation, you include in it a current that has not been used in a previous junction rule equation
  - In general, the number of times the junction rule can be used is one fewer than the number of junction points in the circuit

# Loop Equations from Kirchhoff's Rules

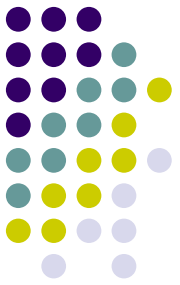

- The loop rule can be used as often as needed so long as a new circuit element (resistor or battery) or a new current appears in each new equation
- You need as many independent equations as you have unknowns

# Kirchhoff's Rules Equations, final

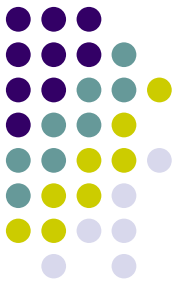

- In order to solve a particular circuit problem, the number of independent equations you need to obtain from the two rules equals the number of unknown currents
- Any capacitor acts as an open branch in a circuit
  - The current in the branch containing the capacitor is zero under steady-state conditions

# Problem-Solving Strategy – Kirchhoff's Rules

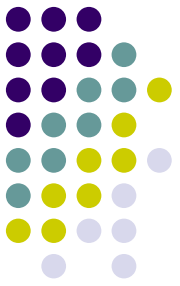

- *Conceptualize*
  - Study the circuit diagram and identify all the elements
  - Identify the polarity of the battery
  - Imagine the directions of the currents in each battery
- *Categorize*
  - Determine if the circuit can be reduced by combining series and parallel resistors
    - If so, proceed with those techniques
    - If not, apply Kirchhoff's Rules



# Problem-Solving Strategy, 2

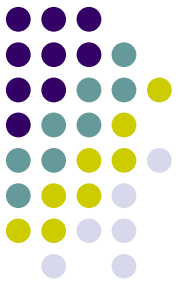

- *Analyze*
  - Assign labels and symbols to all known and unknown quantities
  - Assign directions to the currents
    - The direction is arbitrary, but you must adhere to the assigned directions when applying Kirchhoff's rules
  - Apply the junction rule to any junction in the circuit that provides new relationships among the various currents

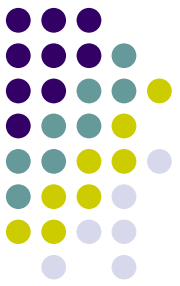

# Problem-Solving Strategy, 3

- *Analyze, cont*
  - Apply the loop rule to as many loops as are needed to solve for the unknowns
    - To apply the loop rule, you must choose a direction in which to travel around the loop
    - You must also correctly identify the potential difference as you cross various elements
  - Solve the equations simultaneously for the unknown quantities
- Draw the circuit diagram and assign labels and symbols to all known and unknown quantities. Assign directions to the currents.
  - The direction is arbitrary, but you must adhere to the assigned directions when applying Kirchhoff's rules
- Apply the junction rule to any junction in the circuit that provides new relationships among the various currents

# Problem-Solving Strategy, final

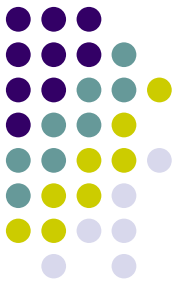

- *Finalize*
  - Check your numerical answers for consistency
  - If any current value is negative, it means you guessed the direction of that current incorrectly
    - The magnitude will still be correct

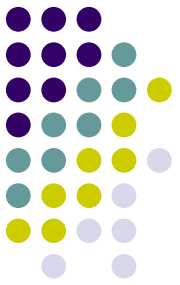

# RC Circuits

- In direct current circuit containing capacitors, the current may vary with time
  - The current is still in the same direction
- An RC circuit will contain a series combination of a resistor and a capacitor

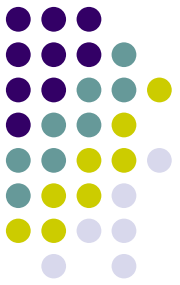

# Charging a Capacitor

- When the circuit is completed, the capacitor starts to charge
- The capacitor continues to charge until it reaches its maximum charge ( $Q = C\varepsilon$ )
- Once the capacitor is fully charged, the current in the circuit is zero

# Charging an RC Circuit, cont.

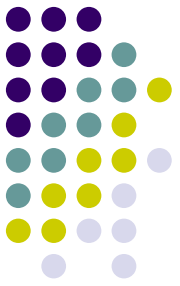

- As the plates are being charged, the potential difference across the capacitor increases
- At the instant the switch is closed, the charge on the capacitor is zero
- Once the maximum charge is reached, the current in the circuit is zero
  - The potential difference across the capacitor matches that supplied by the battery

# Charging a Capacitor in an RC Circuit

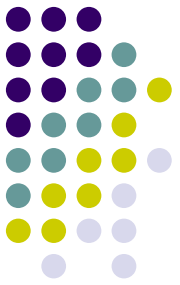

- The charge on the capacitor varies with time

- $q(t) = C\varepsilon(1 - e^{-t/RC})$   
 $= Q(1 - e^{-t/RC})$

- The current can be found

$$I(t) = \frac{\dot{a}}{R} e^{-t/RC}$$

- $\tau$  is the *time constant*
  - $\tau = RC$

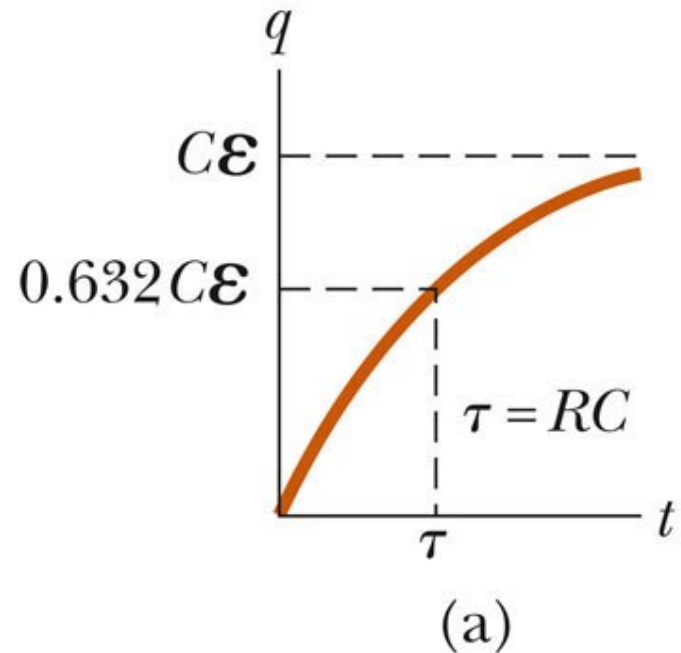

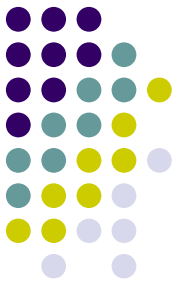

# Time Constant, Charging

- The time constant represents the time required for the charge to increase from zero to 63.2% of its maximum
- $\tau$  has units of time
- The energy stored in the charged capacitor is  
$$\frac{1}{2} Q\mathcal{E} = \frac{1}{2} C\mathcal{E}^2$$



# Discharging a Capacitor in an RC Circuit

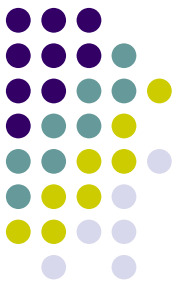

- When a charged capacitor is placed in the circuit, it can be discharged
  - $q(t) = Qe^{-t/RC}$
- The charge decreases exponentially

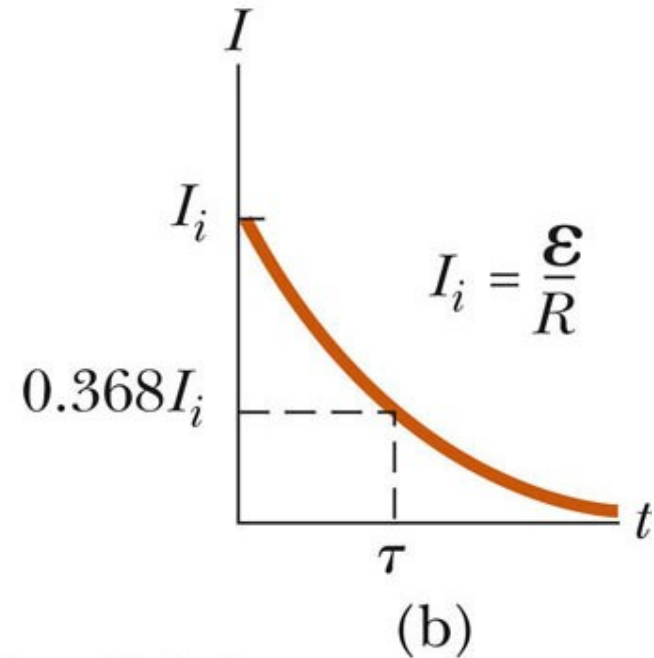

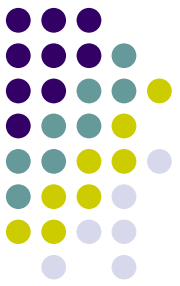

# Discharging Capacitor

- At  $t = \tau = RC$ , the charge decreases to  $0.368 Q_{\max}$ 
  - In other words, in one time constant, the capacitor loses 63.2% of its initial charge
- The current can be found

$$I(t) = \frac{dq}{dt} = -\frac{Q}{RC} e^{-t/RC}$$

- Both charge and current decay exponentially at a rate characterized by  $\tau = RC$

# RC Circuit, Example

- Adjust the values of  $R$  and  $C$
- Observe the effect on the charging and discharging of the capacitor

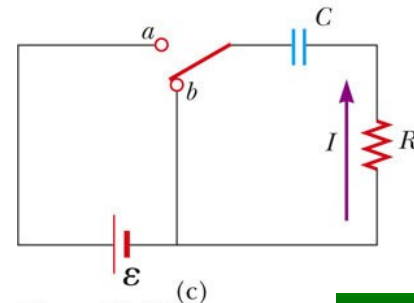
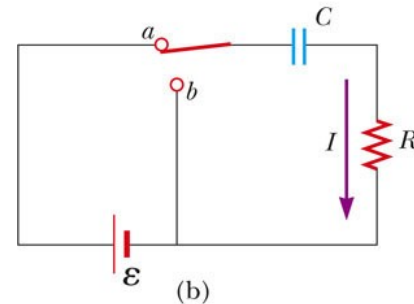
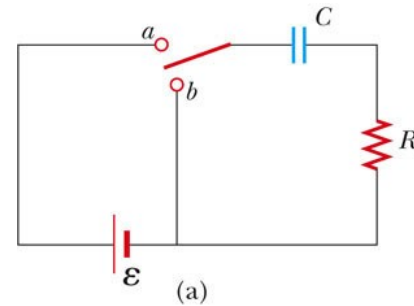

© Thomson Higher Education

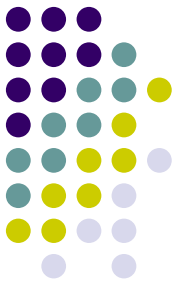

**PLAY  
ACTIVE FIGURE**

# Galvanometer

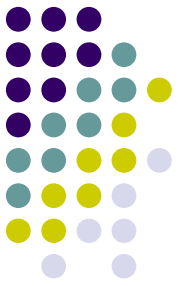

- A galvanometer is the main component in analog meters for measuring current and voltage
- Digital meters are in common use
  - Digital meters operate under different principles

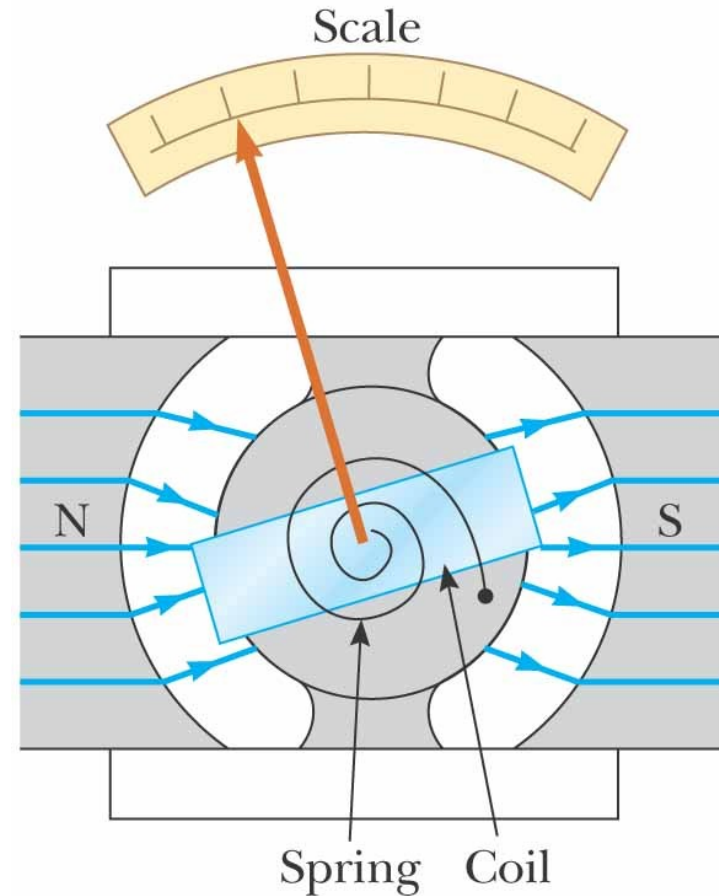

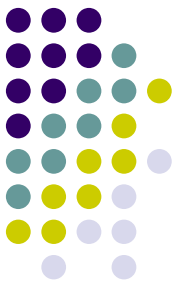

# Galvanometer, cont

- A galvanometer consists of a coil of wire mounted so that it is free to rotate on a pivot in a magnetic field
- The field is provided by permanent magnets
- A torque acts on a current in the presence of a magnetic field

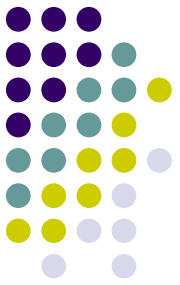

# Galvanometer, final

- The torque is proportional to the current
  - The larger the current, the greater the torque
  - The greater the torque, the larger the rotation of the coil before the spring resists enough to stop the rotation
- The deflection of a needle attached to the coil is proportional to the current
- Once calibrated, it can be used to measure currents or voltages

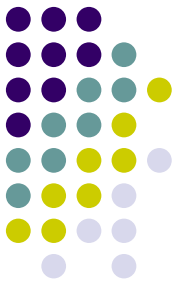

# Ammeter

- An **ammeter** is a device that measures current
- The ammeter must be connected in series with the elements being measured
  - The current must pass directly through the ammeter

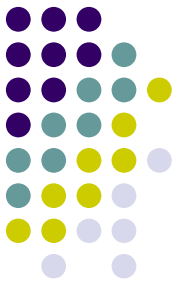

# Ammeter in a Circuit

- The ammeter is connected in series with the elements in which the current is to be measured
- Ideally, the ammeter should have zero resistance so the current being measured is not altered

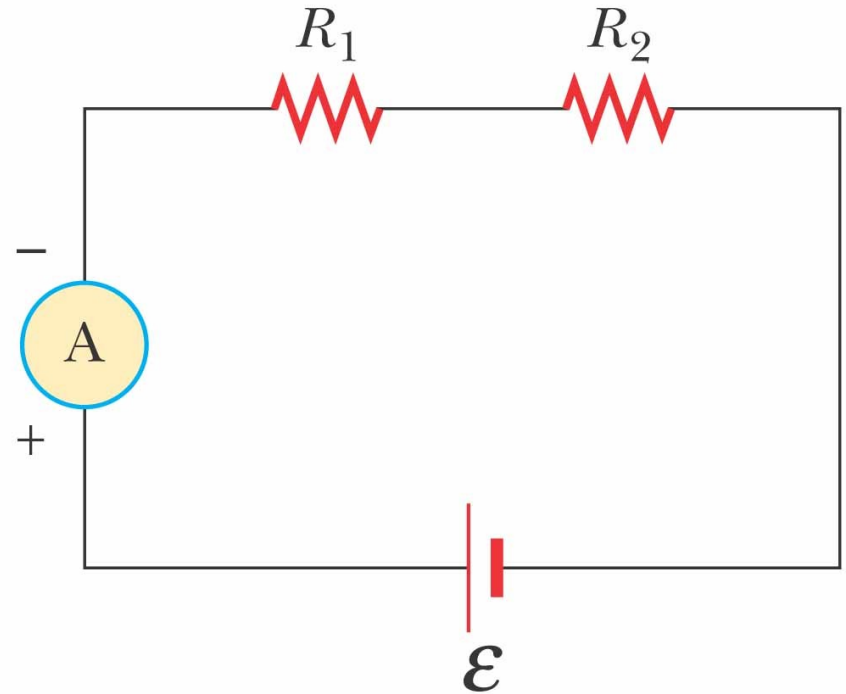



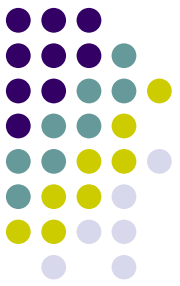

# Ammeter from Galvanometer

- The galvanometer typically has a resistance of  $60\ \Omega$
- To minimize the resistance, a *shunt resistance*,  $R_p$ , is placed in parallel with the galvanometer

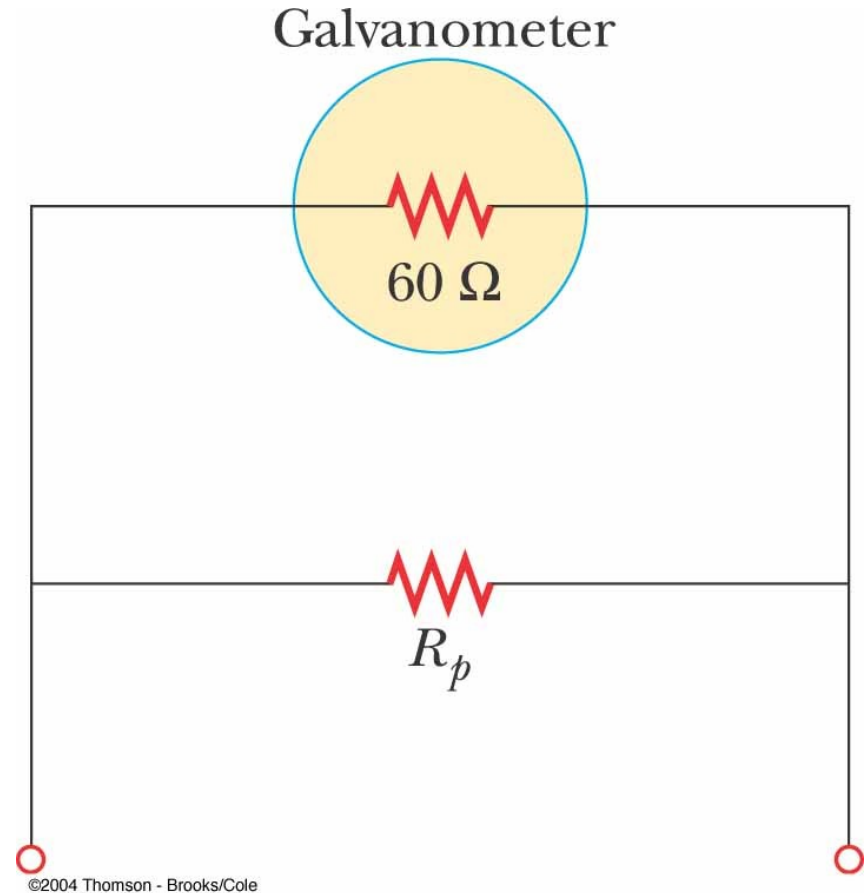

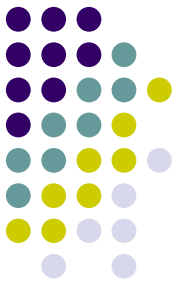

# Constructing An Ammeter

- Predict the value of the shunt resistor,  $R_s$ , needed to achieve full scale deflection on the meter
- Use the active figure to test your result

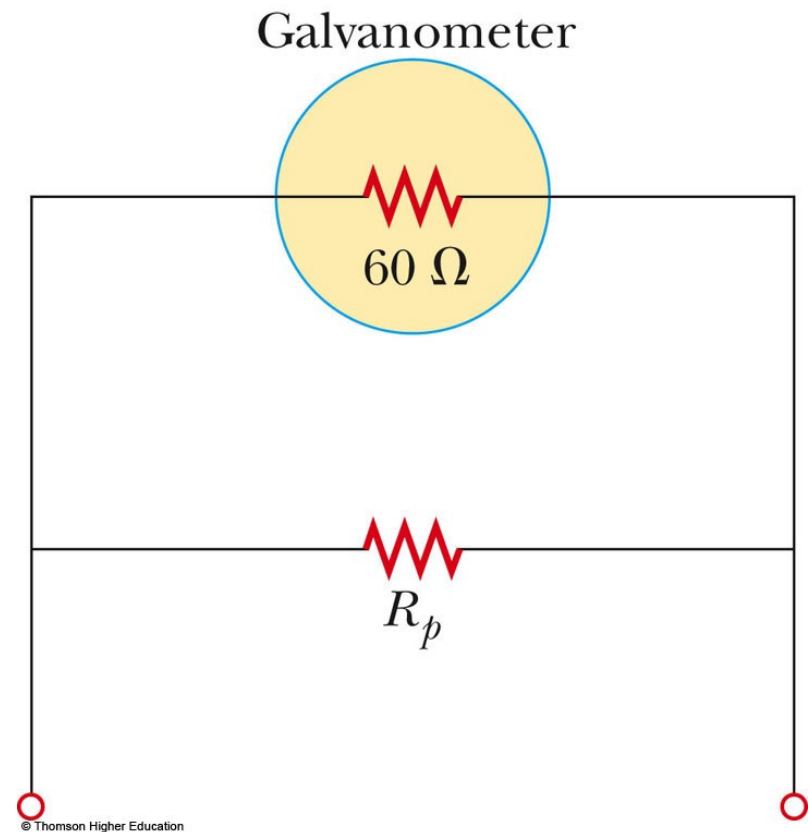

PLAY  
ACTIVE FIGURE

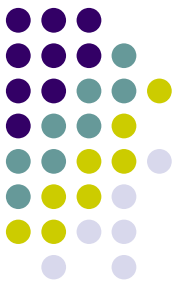

# Ammeter, final

- The value of the shunt resistor must be much less than the resistance of the galvanometer
  - Remember, the equivalent resistance of resistors in parallel will be less than the smallest resistance
- Most of the current will go through the shunt resistance, this is necessary since the full scale deflection of the galvanometer is on the order of 1 mA

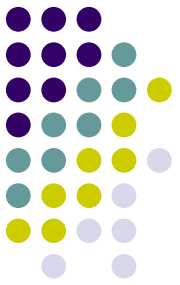

# Voltmeter

- A **voltmeter** is a device that measures potential difference
- The voltmeter must be connected in parallel with the elements being measured
  - The voltage is the same in parallel

# Voltmeter in a Circuit

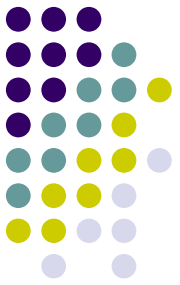

- The voltmeter is connected in parallel with the element in which the potential difference is to be measured
  - Polarity must be observed
- Ideally, the voltmeter should have infinite resistance so that no current would pass through it
  - Corrections can be made to account for the known, non-infinite, resistance of the voltmeter

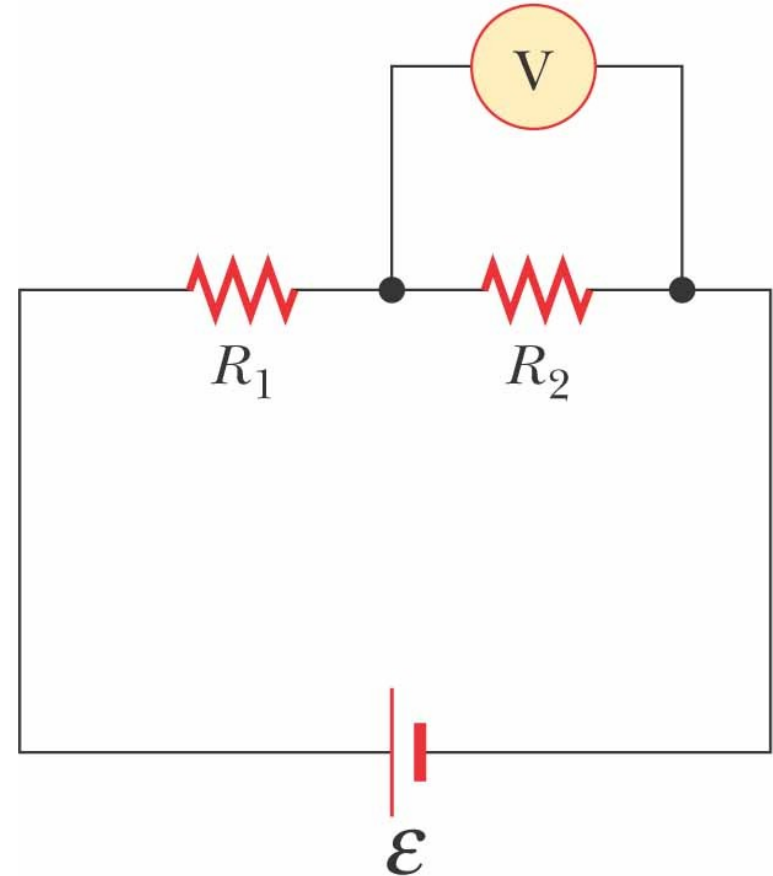

# Voltmeter from Galvanometer

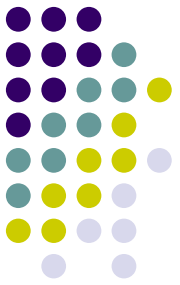

- The galvanometer typically has a resistance of  $60\ \Omega$
- To maximize the resistance, another resistor,  $R_s$ , is placed in series with the galvanometer
- Calculate  $R_s$  and use the active figure to check your result

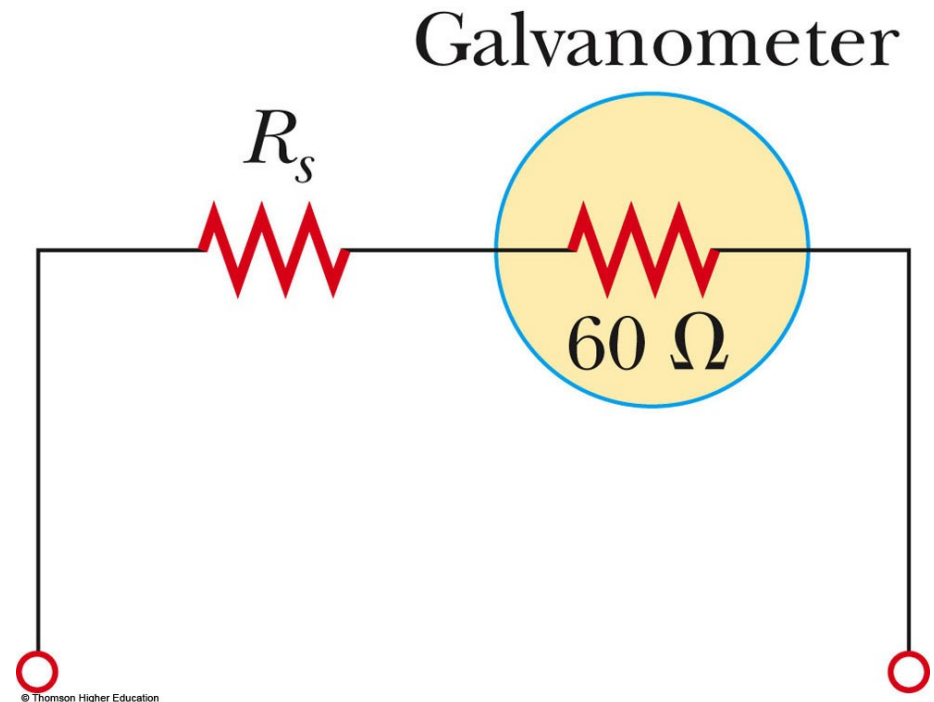

PLAY  
ACTIVE FIGURE

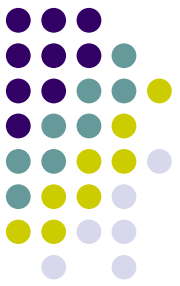

# Voltmeter, final

- The value of the added resistor must be much greater than the resistance of the galvanometer
  - Remember, the equivalent resistance of resistors in series will be greater than the largest resistance
- Most of the current will go through the element being measured, and the galvanometer will not alter the voltage being measured

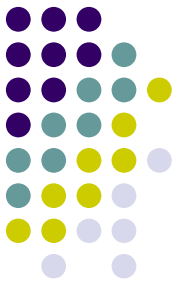

# Household Wiring

- The utility company distributes electric power to individual homes by a pair of wires
- Each house is connected in parallel with these wires
- One wire is the “live wire” and the other wire is the neutral wire connected to ground



# Household Wiring, cont

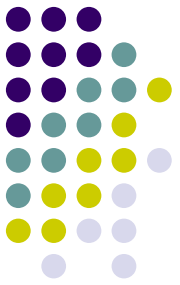

- The potential of the neutral wire is taken to be zero
  - Actually, the current and voltage are alternating
- The potential difference between the live and neutral wires is about 120 V

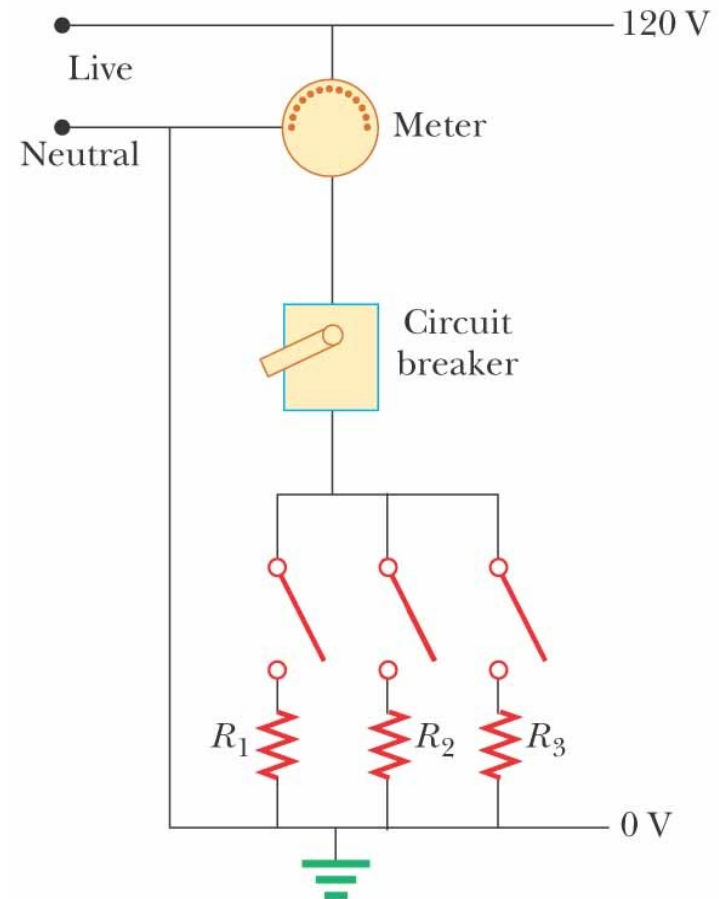

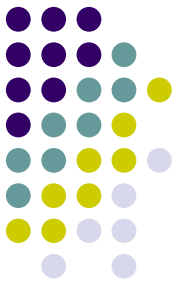

# Household Wiring, final

- A meter is connected in series with the live wire entering the house
  - This records the household's consumption of electricity
- After the meter, the wire splits so that multiple parallel circuits can be distributed throughout the house
- Each circuit has its own circuit breaker
- For those applications requiring 240 V, there is a third wire maintained at 120 V below the neutral wire

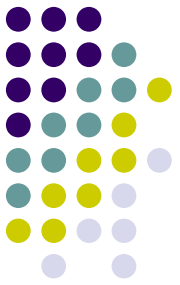

# Short Circuit

- A *short circuit* occurs when almost zero resistance exists between two points at different potentials
- This results in a very large current
- In a household circuit, a circuit breaker will open the circuit in the case of an accidental short circuit
  - This prevents any damage
- A person in contact with ground can be electrocuted by touching the live wire

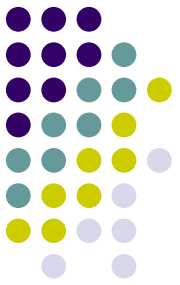

# Electrical Safety

- Electric shock can result in fatal burns
- Electric shock can cause the muscles of vital organs (such as the heart) to malfunction
- The degree of damage depends on:
  - the magnitude of the current
  - the length of time it acts
  - the part of the body touching the live wire
  - the part of the body in which the current exists

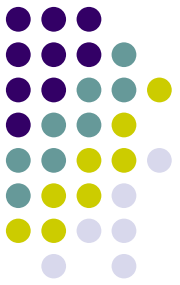

# Effects of Various Currents

- 5 mA or less
  - can cause a sensation of shock
  - generally little or no damage
- 10 mA
  - muscles contract
  - may be unable to let go of a live wire
- 100 mA
  - if passing through the body for 1 second or less, can be fatal
  - paralyzes the respiratory muscles

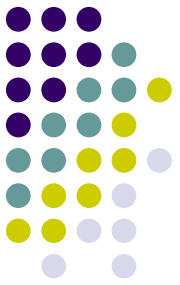

# More Effects

- In some cases, currents of 1 A can produce serious burns
  - Sometimes these can be fatal burns
- No contact with live wires is considered safe whenever the voltage is greater than 24 V

# Ground Wire

- Electrical equipment manufacturers use electrical cords that have a third wire, called a ground
- This safety ground normally carries no current and is both grounded and connected to the appliance

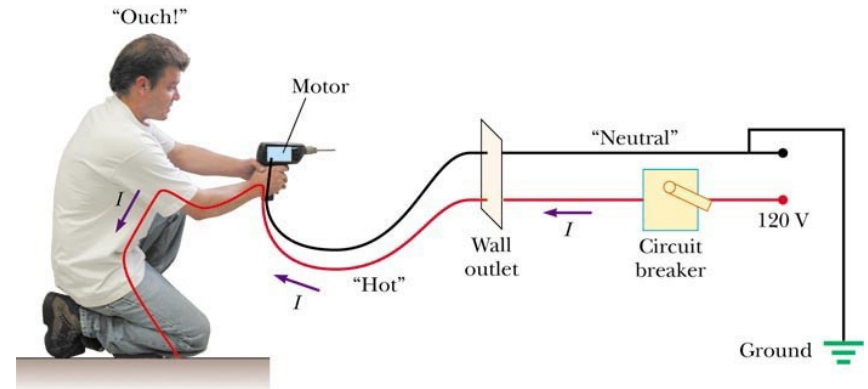

(a)

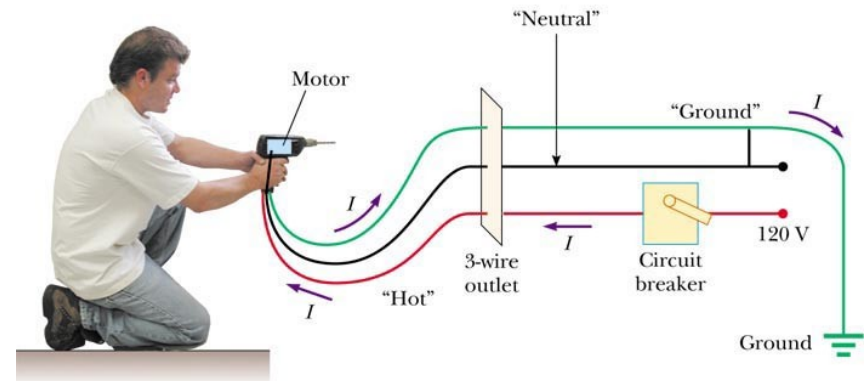

(b)



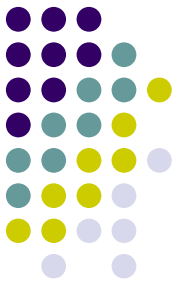

# Ground Wire, cont

- If the live wire is accidentally shorted to the casing, most of the current takes the low-resistance path through the appliance to the ground
- If it was not properly grounded, anyone in contact with the appliance could be shocked because the body produces a low-resistance path to ground



# Ground-Fault Interrupters (GFI)

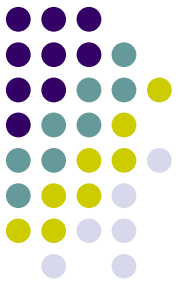

- Special power outlets
- Used in hazardous areas
- Designed to protect people from electrical shock
- Senses currents ( $< 5$  mA) leaking to ground
- Quickly shuts off the current when above this level